

# Affective Umbrella – A Wearable System to Visualize Heart and Electrodermal Activity, towards Emotion Regulation through Somaesthetic Appreciation

Kanyu Chen  
Jiawen Han  
cady.cky@kmd.keio.ac.jp  
hanjiawen@kmd.keio.ac.jp  
Keio University Graduate School of  
Media Design, Japan

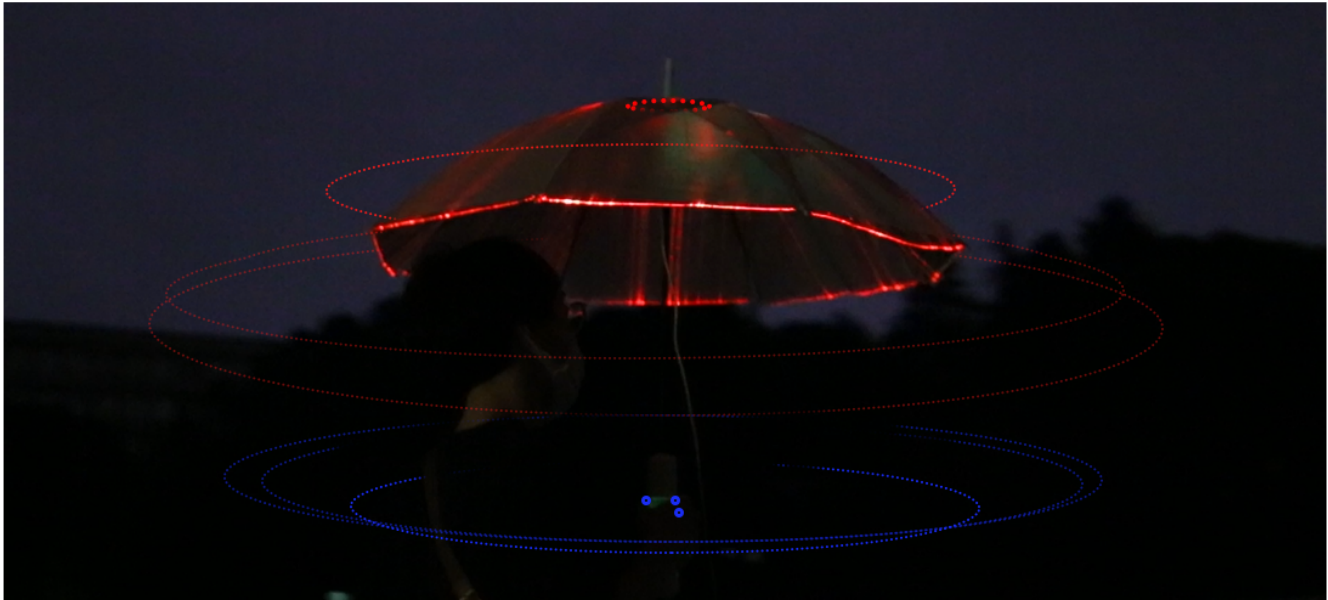
Akira Kato  
kato@kmd.keio.ac.jp  
Keio University Graduate School of  
Media Design, Japan

Holger Baldauf  
Ziyue Wang  
Hoger.baldauf@gmail.com  
mononono39@gmail.com  
Keio University Graduate School of  
Media Design, Japan

Jamie A Ward  
Jamie@jamieward.net  
Goldsmiths, University of London  
United Kingdom

Dunya Chen  
dchen@kmd.keio.ac.jp  
Keio University Graduate School of  
Media Design, Japan

Kai Kunze  
kai@kmd.keio.ac.jp  
Keio University Graduate School of  
Media Design, Japan



**Figure 1: Affective Umbrella: Somaesthetic appreciation through heart activity (light intensity change) and electrodermal activity (number of peaks influence the color) for augmenting emotion regulation in the real world using an umbrella. Dashed line circles illustrate the virtual effect of the device in action around the user.**

## ABSTRACT

In this paper, we introduce Affective Umbrella, a novel system to record, analyze and visualize physiological data in real time via

Permission to make digital or hard copies of all or part of this work for personal or classroom use is granted without fee provided that copies are not made or distributed for profit or commercial advantage and that copies bear this notice and the full citation on the first page. Copyrights for components of this work owned by others than the author(s) must be honored. Abstracting with credit is permitted. To copy otherwise, or republish, to post on servers or to redistribute to lists, requires prior specific permission and/or a fee. Request permissions from [permissions@acm.org](mailto:permissions@acm.org).

*AHs '23, March 12–14, 2023, Glasgow, United Kingdom*

© 2023 Copyright held by the owner/author(s). Publication rights licensed to ACM.

ACM ISBN 978-1-4503-9984-5/23/03...\$15.00

<https://doi.org/10.1145/3582700.3582727>

an umbrella handle. We implement a biofeedback loop design in the system that triggers visualization changes to reflect and regulate emotions through somaesthetic appreciation. We report the methodology, processes, and results of data reliability and visual feedback impact on emotions. We evaluated the system using a real-life user study ( $n=21$ ) in rainy weather at night. The statistical results demonstrate the potential of applying the visualization of biofeedback to regulate emotional arousal with a significantly higher ( $p=.0022$ ) score, a lower ( $p=.0277$ ) dominance than baseline from self-reported SAM Scale, and physiological arousal, which was shown to be significantly increased ( $p<.0001$ ) with biofeedback in terms of pNN50 and a significant difference in terms of

RMSSD. There was no significant difference in terms of emotional valence changes from SAM scale. Furthermore, we compared the difference between two biofeedback patterns (mirror and inversion). The mirror effect was with a significantly higher emotional arousal than the inversion effect ( $p=.0277$ ) from SAM results and was with a significantly lower RMSSD performance than the inversion effect ( $p<.0001$ ). This work demonstrates the potential for capturing physiological data using an umbrella handle and using this data to influence a user's emotional state via lighting effects.

## CCS CONCEPTS

• **Computer systems organization** → **Embedded systems**; *Redundancy*; Robotics; • **Networks** → Network reliability.

## KEYWORDS

wearable sensing, physiological signal, affective computing, biofeedback loop, emotion regulation, interaction design, somaesthetic appreciation design

### ACM Reference Format:

Kanyu Chen, Jiawen Han, Holger Baldauf, Ziyue Wang, Dunya Chen, Akira Kato, Jamie A Ward, and Kai Kunze. 2023. Affective Umbrella – A Wearable System to Visualize Heart and Electrodermal Activity, towards Emotion Regulation through Somaesthetic Appreciation. In *Augmented Humans Conference (AHS '23), March 12–14, 2023, Glasgow, United Kingdom*. ACM, New York, NY, USA, 12 pages. <https://doi.org/10.1145/3582700.3582727>

## 1 INTRODUCTION

Have you ever suddenly felt a strong emotion, maybe triggered by a smell, a sound, an event, or other environmental factors? Generally, emotion refers to specific negative and positive affective states[22]. The process of emotion is a complex chain of loosely connected events, triggered by a stimulus, dynamic changes in the level of cognitive load, and physiological arousal, then reacting as specific, goal-directed behaviors[49].

Understanding ourselves, our physiology, and our affective states is not easy. It is even more difficult to regulate our feelings. We have seen the effective use of several meditation practices[14] to help with increasing stress and to enable emotion regulation. These have their practitioners focus on their breath or on an object or its movement, etc., to enable them to observe their feelings from "the outside". In our research, we follow a related, but distinct approach using somaesthetic appreciation design to augment the ability of understanding and regulating emotional feelings [27]. We externalize physiological signals of the user and display these signals in the environment or on devices the users wear. With these augmentation methods, we seek to give the user time to reflect on their own physiology and link external triggers to their feelings.

In this paper, we focus on understanding and regulating people's emotions through somaesthetic appreciation in a real-world context of a rainy day. We believe that umbrellas could be potential augmentations to help people regulate their emotions even when they are not comfortable [35] during rainy days and encourage people to walk outdoors with more pleasant emotion [32] further exploring the links between their physiology and different contexts. We present an initial umbrella design that takes heart rate variability (HRV) and electrodermal activity (EDA) of the user and displays

light and color feedback on the umbrella itself as a first artifact to enable emotion regulation via somaesthetic appreciation design, thus externalizing the user's physiology in a visualization.

The contributions of this work can be summarized as follows: (1) We describe a novel biofeedback system to augment experiencing and adjusting emotional feelings by using our customized wearable device – Affective Umbrella. Our system integrates sensing (EDA and BVP data), processing, and visualizing modules. We also describe the detailed design and evaluation process during prototype iterations, which could help HCI researchers develop similar biofeedback installations. (2) We present a relatively real-life user study which 21 participants attended. Participants were asked to use Affective Umbrella while walking in the rain. Based on the feedback collected, we prove the potential of using Affective Umbrella to augment affective experience and provide discussions about different biofeedback patterns that could imply for future biofeedback loop design. (3) We provide a feasible method of evaluating the biofeedback system including survey, interview, and physiological data analysis. We will make the dataset (BVP and EDA data collected during three phases of this study) freely available under the link: <https://osf.io/sg5pt/>.

## 2 RELATED WORK

### 2.1 Modeling and Regulating Emotions

Emotion is a complex and often ambiguous internal process that can be difficult, if not impossible, to measure and communicate. With the concept of emotion models, we can approximate a relatively feasible method to understand emotions quantitatively [49]. There are several widely adopted established emotion models. Mehrabian and Russel developed the PAD (Pleasure, Arousal, and Dominance) emotional state model to represent emotions [43, 52]. In the PAD model, emotions are mapped to three dimensions: Pleasure/Valence, Arousal, and Dominance [43]. Lang et al. developed the nonverbal, pictorial self-assessment manikin (SAM) based on the PAD model [42]. PAD model [52] provides this study as the scientific and fundamental support to assess the emotion.

Affective experience and emotion have become trending research directions in the field of HCI [2, 13, 29, 47, 54, 64, 67]. Lin et al. use a conditioning effect to trigger deep breathing exercises over scent when a person is in a stressful situation [38]. Similar to our concept, Cochrane et al. present a design method of adjusting the emotional reality of a user to regulate emotions. They also adopted EDA as the sensing modality in biofeedback [14]. However, the authors focus mostly on the design process and applications towards mental health. Additionally, Sabinson et al. present work toward a robotic surface for emotion regulation through tactile, expressive movement in closed spaces [53] which differs from our focus on visual lighting feedback. In addition to body sensing, there are also other interventions and approaches for emotion regulation (e.g., guided exercises to video games)[54, 67].

### 2.2 Physiological Sensing

Emotions that humans experience while interacting with their environment are associated with varying degrees of physiological arousal, where the autonomous nervous system (ANS) plays a crucial role [5, 37]. Emotional states associated with ANS responses can

be inferred using physiological data like electrocardiography (ECG), electroencephalography (EEG), electrodermal activity (EDA), and blood volume pulse (BVP) [8, 55]. In this work, we focus on EDA and BVP because these can be obtained from sensors touching the hand.

EDA, also known as skin conductance (SC), refers to the change in the electrical conductance properties of the skin in response to the change in sweat secretion rates by the sweat glands [6, 66]. EDA measurements mostly concentrate on two parameters: skin conductance response (SCR) - rapid changes (on the scale of seconds) in response to emotional or stress stimuli; and skin conductance level (SCL) - slow changes (within minutes and hours) commonly associated with the general condition of the subject. In recent decades, skin conductance has been one of the most sensitive markers and is frequently used to assess emotional arousal, as the skin conductance response activity increases when emotional arousal increases. [3, 9, 36, 66].

Heart rate variability (HRV) describes the changes in time intervals between each consecutive pair of heartbeats [56]. HRV is often used to evaluate the activity of the autonomic nervous system, namely two of its branches, the sympathetic and parasympathetic nervous systems (SNS and PSNS, respectively). Simply put, it demonstrates how the neural structures of the prefrontal cortex regulate the activity in limbic structures that modulate the balance between PSNS and SNS by inhibiting the PSNS and activating the neural circuitry of the SNS. Since the prefrontal cortex is closely linked to cognitive and psychological processes, it is possible to see reflections of the cognitive and emotional states of a subject in its HRV. When the HRV value increases, it indicates that the participant becomes more relaxed. In contrast, when the HRV value decreases, the participant becomes less relaxed and more tense, as this signifies the activation of the SNS that moderates the fight-or-flight response [50].

### 2.3 Linking Biofeedback and Emotions

Biofeedback is a concept that expresses the idea of externalizing physiological signals [20, 33, 44, 69]. Physiological signals such as EEG [24, 25], EDA [61], and heart rate (HR) [16, 57] can be applied to biofeedback design to reflect emotional situations. For example, Cochrane et al. facilitate mindful walking meditations over a soundscape using EEG signals [15]. Gollob et al. also use EEG to estimate and explore physical aesthetic possibilities [21]. Mladenovic et al. look into how to use electrodes for gut biofeedback in emotion regulation applications [44]. The AmbienBeat system from Choi and Ishii applies tactile feedback based on heart rate sensing for rhythmic biofeedback regulation [12]. In the context of umbrella-based interaction, prior research has explored various interactive technologies to improve sensory experiences, focusing mainly on raindrop energy conversion and remote haptic sharing [19, 31, 46], sound modality based auditory space [19, 30], and visually, using the umbrella surface as an Internet-enabled interactive screen [10, 41, 45], etc.. However, we are not aware of any somaesthetic experiences that have tried to down-regulate an individual's feeling of discomfort when using the umbrella. Based on the previous work [11], Affective Umbrella is designed to provide

a biofeedback experience via intuitive color changes triggered by both EDA and BVP data input.

## 3 DESIGN

To demonstrate our vision, we constructed the Affective Umbrella, a novel umbrella-based wearable platform that uses real-time biofeedback to encourage emotion regulation in users. We applied an *iterative design approach* in the construction, and evaluated the feasibility of both the sensing and feedback components.

### 3.1 Implementation

The Affective Umbrella system consists of 1) an umbrella-based wearable physiological sensing form factor, 2) a data streaming system for data recording and emotion detection, and 3) two modes of biofeedback display for emotion reflection and regulation.

**3.1.1 Form Factor.** We embedded sensors within a 3D printed umbrella handle. The form of our design is inspired by prior work on interactive umbrellas [18, 19, 40, 41, 45]. We chose a handle form factor also because of its non-invasive position for detection of EDA and BVP, the possibility for ubiquitous wear, and easy activation in needed scenarios. The 3d printing material is made of polylactic acid (PLA), a light, hard, and environmentally friendly polymer. The placement of the EDA electrodes was chosen to be in line with our habits of holding an umbrella; the EDA sensors are placed diagonally on the umbrella handle, matching the position of the palm: under the thumb and under the pad of the index finger; the BVP plethysmograph is located under the middle finger. Through the sensing test (see in Figure 5), it is found that a certain degree of movement and grip changes when holding the umbrella have negligible interference effects on overall data collection.

In addition to the design of the sensing part, for the implementation of the interactive experience, we use visual feedback to represent dynamic emotion arousal [58, 65] based on biometric feedback on the balanced results of the subjective and objective interpretation of our iterative feedback test. The system uses a string of 8 RGB LEDs connected through fiber optic fabric on the inside of the umbrella surface, which was programmed to display red or blue light.

**3.1.2 Hardware and Data Streaming.** The umbrella side consists of two M5Stick CPlus boards (ESP32-A and ESP32-B, Figure 3) that use the ESP32 chip to receive weather-related data (temperature, humidity, rainfall data) from DHT11 and rain sensors and physiological data (EDA and BVP data) from biometric sensors accordingly. By applying a client-server model, data are streamed wirelessly to computers running in-house software as a data receptacle over UDP. The client of the umbrella sends message packets to a PC server, collecting weather-related data on the ESP32-A and physiological data from the EDA sensor and the BVP sensor on the ESP32-B. The PC records the raw data into a .csv file and streams the SCR feature from the raw EDA data to represent emotion arousal in real-time. Real-time analysis sends back the message to address RGB LED strips on the ESP32-A to control the color of the light of the LEDs connected to the fiber optic fabric (see Figure 3).

**3.1.3 Biofeedback Pattern.** Besides displaying the LED color based on real-time arousal data analysis every 20 seconds from



Figure 2: Affective Umbrella: sensing handle and visual biofeedback

peaks of skin conductance response (SCR peaks), the brightness pattern with the heartbeat simulated light effect was added as real-time biofeedback, designed to regulate the user’s emotion by augmenting their somaesthetic appreciation. We give users different psychological cues through changes in the color and speed of fading brightness by setting the LED color switching between blue (RGB parameter: (0,0,255)) and red (RGB parameter: (255,0,0)) [58, 65], and brightness parameters ranging from 0 to 255. A relative increase over the prerecorded 20 seconds is considered higher arousal (color change to red; the more SCR peaks, the faster the red intensity); and a lower rate changes the color to blue (the lower the rate of SCR peaks, the slower the blue intensity). It represents the current dynamic emotional arousal and would be tested as mirror effect in the following user study. Considering the relativity of physiological arousal caused by color (according to the results of the feedback test analysis), we assumed that a reversed brightness change of the color could help to regulate physiological arousal, based on earlier work[65]. Therefore, we inverted the brightness fading effect compared to the mirror effect (later referred to as inversion effect in the user study). The EDA analysis is based on related work presented in the previous section [6, 66].

### 3.2 Iterative Method

The design and evaluation of the system is split into three phases (See in Figure 4).

- Phase 1 involved a sensing test to assess the suitability of the handle sensing and the quality of the physiological data.
- Phase 2 involved feedback testing to measure and explore the impact of different umbrella color effects[65] on user emotion.
- Phase 3 was an outdoor user study carried out during a rainy evening to better understand how users are affected by different real-time biofeedback effects under real-world conditions.

To drive the iteration, the design was evaluated based on a balance analysis of arousal data between self-report and physiological data regarding biometric sensing, color feedback on emotions, and user study. Statistical analyses were carried out using GraphPad Prism 9.4.0 software[60]. Therefore, the physiological data pre-processing and analysis method will be briefly described below.

**3.2.1 Pre-processing of EDA and BVP.** Each participant’s raw EDA data is passed through a 2<sup>nd</sup> order Butterworth low-pass filter from the *scipy.signal* package [68] to cut high frequency noise above 0.5 Hz[48, 68]. We also decompose the EDA signal into its tonic and phasic components and especially focus on peaks in phasic changes, which were shown to be related to sudden aroused feelings [9] - known as SCR peaks (Tonic, Phasic, Aggregated SCR Peak in Table 1).

HRV features are extracted from BVP data through a 4<sup>th</sup> order Butterworth low-pass filter from the *scipy.signal* package [68] to cut high frequency noise above 3.5 Hz[48, 68]. HRV features were calculated every 1s with a two-minute sliding window. The HRV features were divided by mean RR intervals of each participant for normalization to remove baseline differences between individuals [19, 74, 75].

According to the feature importance for iterative evaluation, we selected the following features and normalized the value in Table1 to remove individual differences:

- **Tonic:** EDA Tonic skin conductance Level (SCL) components.

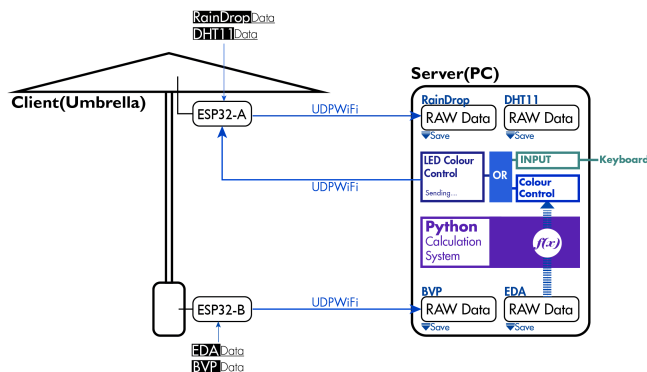


Figure 3: Data communication in streaming system



**Figure 4: Design process in three phases. (a) Phase 1: User and umbrella, setup in the sensing test. (b) Phase 2: Umbrella in action in the feedback test. (c) Phase 3: Interaction use case; umbrella visualizes heart activity (light intensity change) and electrodermal activity (number of peaks influence the color) in the user study.**

- **Phasic:** EDA Phasic skin conductance response (SCR) components.
- **SCR Peak:** Peaks of skin conductance response or phasic components of EDA.
- **pNN50:** The percentage of adjacent NN intervals that differ from each other by more than 50 ms.
- **RMSSD:** The root mean square of successive differences between normal heartbeats.

In the following sections, we will introduce the procedures for each phase and then the results.

## 4 PHASE 1: SENSING TEST

### 4.1 Procedure

A sensing test was performed to collect emotion-related arousal data, using a BVP sensor and EDA sensors, which was then compared with the baseline placement of a wristband which was used in similar research [7, 17, 34, 59].

8 participants aged from 23 to 32 years old (mean: 27.13, SD: 2.66, female:4, male:4) were recruited for this study. A written informed consent form including a statement on ethics approval was provided to all participants prior to their participation. The test included two 7-minute sessions and an 8-minute interview at the end. During the test, participants were required to hold the umbrella in the dominant hand and wear the wristband on the other hand while being exposed to audio stimuli over wireless Bluetooth headphones. We recorded EDA (4.54 Hz) and BVP (50 Hz) data alongside the Self-Assessment Manikin (SAM) scale to different contexts during which the participants listened to affective audio effects. Early work usually used jump scare sound effects [62] as feasible stimuli to explore a rapid change in physiological arousal. The participants were informed before the experiment that they would be exposed to jump scare effects. We used audio from the youtube audio library <sup>1</sup>.

To specify the feasibility of arousal data from the handle, it was first investigated by comparing the averaged and baseline-corrected physiological arousal levels elicited in response to a jump scare event between the individual.

<sup>1</sup>Jump Scare Sound Effects: 2016. [youtube.com/watch?v=ZWI2hMO6LNM](https://www.youtube.com/watch?v=ZWI2hMO6LNM). Accessed: 2022-12-09.

## 4.2 Initial Results

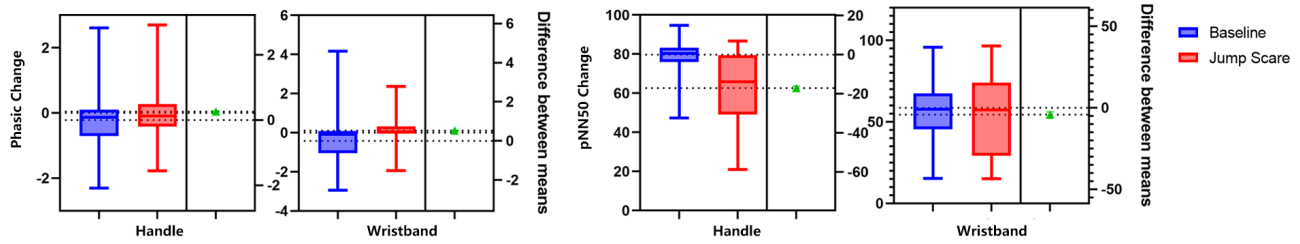
For comparison of EDA and HRV data under the jump scare effect, a Pearson correlation coefficient was calculated to assess the linear relationship between the wristband and the handle. The pNN50 signals were highly correlated ( $r(1155) = .825, p < .0001$ ), though aggregated SCR peaks revealed negligible correlation ( $r(7358) = .154, p < .0001$ ). Comparable arousal trends showed that participants experienced an average higher arousal (see Table1) under the jump scare effect than in the baseline over Phasic (wristband:  $t(15248) = 35.23, p < .0001$ ; handle:  $t(15508) = 18.77, p < .0001$ ) and pNN50 (wristband:  $t(2795) = 4.86, p < .0001$ ; handle:  $t(2647) = 33.81, p < .0001$ ), which were analyzed using an unpaired two-tailed t-test. Aggregated arousal results under the jump scare (Mean:4.63, SD:2.88) from SAM scale was much higher than the baseline (Mean:1.50; SD:0.76).

Therefore, the umbrella handle was capable of collecting consistent and accurate physiological signals compared to the baseline device.

## 5 PHASE 2: FEEDBACK TEST

### 5.1 Procedure

Based on self-report findings over PAD model [65] and motivated by the Moodlight idea [58] of choosing the colors that represent arousal states from previous studies, the feedback test was designed to better understand psychophysiological arousal responsiveness on blue and red color (selected to test the increasing effect of the emotional valence and extreme difference of emotional arousal) through the umbrella in a lab-controlled setting. 18 participants aged from 21 to 38 years old (Mean: 26.8, SD: 3.258, Female:9, Male:9) were recruited for the feedback test. We recorded EDA (4.54 Hz) and BVP (50 Hz) data alongside the Self-Assessment Manikin (SAM) scale to different colors. We counterbalanced three sessions (each 6 min): a baseline session without visualization (no-viz), a blue session (blue), and a red session (red). The participant was required to hold the handle with their dominant hand and was exposed to the differently colored light stimuli. A 5-minute interview was conducted at the end of the test. A written informed consent form was provided to all participants prior to their participation.



**Figure 5:** Two graphs on the left: trends in all subjects for Phasic Change (Left Y scale) and difference between means (Right Y scale); two graphs on the right: trends in all subjects for pNN50 Change (Left Y scale) and difference between means (Right Y scale) over the handle and the wristband.

## 5.2 Results and Implications for emotion regulation

As for the physiological arousal results, according to a repeated measure of ANOVA, mean arousal changes of Phasic ( $F(2, 47590) = 124.6, p < .0001$ ) and pNN50 ( $F(2, 4250) = 84.86, p < .0001$ ) through the handle differed significantly over the three sessions; there was no significant difference ( $F(2, 47590) = 1.970, p = 0.1395$ ) in terms of changes in aggregated SCR peaks. As reported in Table 1, average Phasic in the blue session (Mean: 6.62, SD: 16.90) showed higher emotional arousal than in either baseline (Mean: 5.40, SD: 10.26) or red session (Mean: 4.42, SD: 8.67) but average pNN50 in blue session (Mean: 75.83, SD: 23.30) indicated it as the highest relaxation state compared to the baseline (Mean: 83.31, SD: 8.10) and red session (Mean: 82.28, SD: 14.85).

The interview transcripts in each session were processed with three elements (neutral, positive, negative score, and total score is 1) through the nltk package [23] for semantic sentiment analysis. Taking the no-viz effect as the baseline (neutral score of no-viz: Mean(0.70), SD(0.14); of blue: Mean(0.63), SD(0.14)); of red: Mean(0.53), SD(0.20), the positive self-report score for the blue effect (Mean:0.35, SD:0.15) is higher than for the red effect (Mean:0.29, SD:0.23), and both blue and red are higher than in the no-viz session (Mean:0.12, SD:0.14). However, the negative score for the blue effect (Mean:0.014, SD:0.03) is much lower than that for the red effect (Mean:0.17, SD:0.23) compared to the no-viz session (Mean:0.12, SD:0.14). The following aesthetic appreciation quotes serve as examples from the blue (subject 13)/red sessions (subject 10 and 2) (stream of consciousness, slightly adjusted for grammar):

*"...blue, a bit of a feeling of being under the stars, the milky way, beautiful, I enjoyed the whole 6 min watching the Milky Way. It brings me to have a layer of richer imagination, comfortable, peaceful situation." (subject 13)*

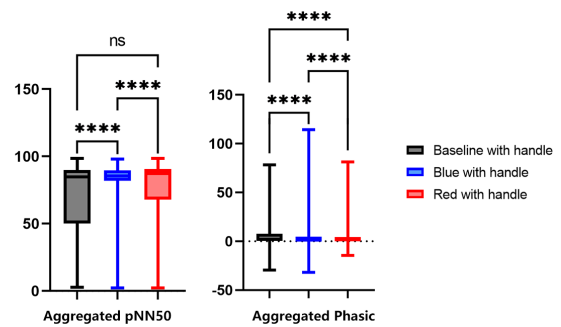
*"Red is more joyful, but also gets me a bit anxious." (subject 10)*

*"In video games, red is associated with a strong sense of warning, especially when being isolated in the dark." (subject 2)*

For the SAM results, we found that the subjective feeling of the participants during the blue session is positive, whereas it is negative during the red session. Mean score in valence change:

no-viz (-0.52)/blue(0.29)/red(-0.59); in arousal change:(-0.47)/blue(-0.35)/red(0.77). The interview and SAM results help explain the effects of the two different colors on physiological arousal within the different color sessions. Basically, blue appeared to have a positive effect on the emotional state, while red shows relatively negative effects on the emotional state and the physiological arousal change.

Overall, 14 participants thought the red and blue extremes accurately depicted their maximum stress and relaxation states, respectively, while 1 participant thought the opposite, and 2 participants agreed that the red brought them more calmness. 1 participant neither agreed nor disagreed with their emotions being affected by the red and blue.



**Figure 6:** Left graph shows the trends in all subjects of Aggregated pNN50 (Left Y scale); Right graph shows the trends in all subjects of Aggregated Phasic Change (Left Y scale) over three sessions: baseline, blue and red. Symbols: ns =  $p > 0.05$ ; \*\*\*\* =  $p < 0.0001$ .

## 6 PHASE 3: RAINY DAY USER STUDY

The main objective of this study is to examine how biofeedback patterns (mirror and inversion) will elicit a regulated affective state in a real-world setting. The affective umbrella assesses the emotional reaction using self-reported measures and a biometric measure (BVP and EDA) over the handle. We conducted an outdoor user study on a rainy evening. Lastly, the link between biofeedback patterns and biometric feature (HRV and EDA) shall be examined. The corresponding research questions (RQs) are the following:

**Table 1: Descriptive statistics of HRV and EDA features over different conditions in the iterative phases, respectively.**

Condition Type		PNN50 Mean(SD)	Tonic Mean(SD)	Phasic Mean(SD)	Aggregated SCR Peak Mean(SD)
Sensing Test (n=8)	Baseline with handle	79.75 (6.77)	52.43 (3.93)	-.22 (.83)	.0011 (0.0338)
	Baseline with wristband	58.68 (20.53)	74.00 (97.36)	-.42 (1.14)	.0004 (.0195)
	Jump Scare with handle	62.66 (17.95)	50.29 (6.50)	.04 (.88)	.0009 (.0302)
	Jump scare with wristband	54.45 (25.50)	110.10 (150.90)	.10 (.59)	.0008 (.0285)
Condition Type		PNN50 Mean(SD)	Tonic Mean(SD)	Phasic Mean(SD)	Aggregated SCR Peak Mean(SD)
Feedback Test (n=18)	Baseline with handle	75.83 (23.30)	35.34 (26.60)	5.40 (10.26)	.0011(.0334)
	Blue with handle	83.31 (8.10)	72.30 (28.02)	6.62 (16.90)	.0005 (.0214)
	Red with handle	82.28 (14.85)	30.22 (32.36)	4.42 (8.67)	.0009(.0294)
Condition Type		Normalized PNN50 Mean(SD)	Normalized RMSSD Mean(SD)	SCR peaks counts Mean(SD)	
Rain Day User Study (n=21)	Baseline	.110 (.031)	.479 (.308)	25.00 (9.94)	
	Random	.026 (.021)	.100 (.035)	23.39 (9.00)	
	Mirror	.097 (.027)	.422 (.208)	22.89 (13.23)	
	Inversion	.098 (.035)	.572 (.591)	24.39 (10.92)	

RQ1: Do the different visual biofeedback patterns succeed better in regulating emotion (valence, arousal, dominance) than no biofeedback patterns?

RQ2: Is there a significant difference between mirror and inversion effect towards emotion regulation?

RQ3: How do participants interpret their experience with different visual feedback?

## 6.1 Materials and Methods

**6.1.1 Participants.** 21 participants aged from 21 to 40 years old (female:10, male:11) were recruited in this study. The experimental design (as with previous studies) was blinded for review, submitted to the ethics board, and subsequently approved. Demographic information and attitudes towards certain weather types were collected. Each participant received a 1000 JPY gift card as compensation.

**6.1.2 Experimental Procedure.** We explained the experimental procedure to the participants and started the experiment after receiving their consent. There were four sessions in total, and the order was counterbalanced. Each session lasted 5 minutes with no specific tasks. The participants were asked to stroll in the rain. We suggested that each participant walk freely or stand around holding the umbrella with their dominant hand in outdoor environments. Before and after each session, participants' emotional states were recorded by self-report (SAM scale). We had a check-out interview to ask about the participants' interpretation of the visual patterns and also invited participants to share their feelings after each session while drawing body maps [4, 39]. For the experimental setting of this study, four conditions are described as follows:

- Baseline: no visual feedback.
- Random: random color, flicker feedback every 20 s.
- Mirror: visual feedback every 20 s corresponding to Phasic EDA change in the previous 20 s; red, fast flashing light or blue, slow flashing light.
- Inversion: visual feedback every 20 s; blue, fast flashing light or red, slow flashing light.

**Table 2: Descriptive statistics of three emotional dimensions mean changes (valence/arousal/dominance) over four conditions.**

Condition Type		Valence Mean(SD)	Arousal Mean(SD)	Dominance Mean(SD)
Rain Day User Study (n=21)	Baseline	.47 (1.37)	-1.19 (1.94)	1.86 (2.31)
	Random	.76 (1.55)	.24 (2.32)	-.33 (2.18)
	Mirror	.43 (1.12)	1.05 (1.60)	.19 (1.81)
	Inversion	.43 (1.94)	-.19 (1.89)	-.10 (2.26)

## 6.2 Results: Affective Dynamics with Biofeedback

**6.2.1 Self-reported Results.** In terms of self-reported SAM scores, participants would show higher emotional arousal and lower dominance scores when they are experiencing biofeedback patterns than no visualization in the baseline session. And most of the participants were aware of the difference in manipulation between the random session and the biofeedback sessions (mirror and inversion).

We calculated changes in valence, arousal, and dominance scores during each condition and performed a statistical analysis to answer the research question (RQ1-RQ3). According to a repeated measures of ANOVA, mean changes at the dimensions of arousal ( $F(2.419, 48.39) = 5.632, p=0.0040$ ) and dominance ( $F(2.081, 41.62) = 3.743, p=0.0305$ ) significantly differed across the four conditions. There was no significant difference in terms of valence changes ( $F(2.781, 55.63) = 0.2428, p=0.8522$ ). We also conducted pairwise comparisons (see Figure 7) and found that the arousal change in the mirror session was significantly higher than that in both baseline ( $p=0.0022$ ) and inversion session ( $p=0.0277$ ). Regarding changes in the dominance level, the baseline session was significantly higher than the mirror session ( $p = 0.0479$ ) and the inversion session ( $p = 0.0268$ ).

The results of the psychological arousal change ( $p=0.0022$ ) based on the visualization of emotion reflection and previous research[28] support each other, indicating that the biofeedback pattern design we used for emotion reflection is confirmed. Furthermore, participants would show a significantly lower score in terms of emotional arousal when experiencing the inversion effect ( $p = 0.0277$ ) than the mirror effect. Participants would show a significantly higher

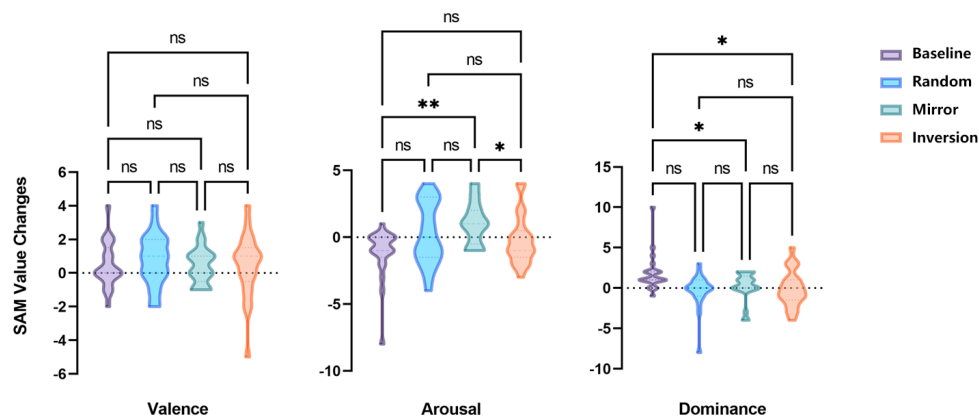


Figure 7: SAM changes over four conditions. Symbols: ns =  $p > 0.05$ ; \* =  $p < 0.05$ ; \*\* =  $p < 0.01$ .

score in terms of emotional arousal when experiencing the mirror effect ( $p=0.0022$ ) than without it.

Regarding the interpretation of visual feedback by participants from check-out interviews, 16 participants thought that the visualization did not change related to their feelings at all in the random sessions. Participants would judge whether the visual feedback is random by feeling their heartbeat or sweat change in their bodies, and they would try to control the color (see example quotes from participants below; slightly altered for grammar).

"This time i think the umbrella is trying to play with me, because apparently it is not correspondent with me. But generally, I had fun using." (subject 2)

"The color and pace seemed to sometimes change according to my heartbeat, but generally, the visualization felt quite random." (subject 6)

"I did not feel related to the change in color, but it influenced how I feel..." (subject 13)

"I tried to control the color changing but failed, and the actual application scenario was simulated after giving up, very good, with a commercial future, my feeling returned to the feeling before the experiment." (subject 16)

"...repeatedly change depending on the preset." - (subject 21)

Although participants were told about the biometric sensing on the umbrella handle, most participants guessed whether it was related to themselves by feeling their body state, such as changes in heartbeat and the cognitive relationship to the color. In the mirror session, 14 participants thought the visualization represented part of their feeling, and 6 participants thought they felt being influenced rather than being represented, while 1 thought it was not related to his feeling:

"I felt that the visualization and my feelings interacted with each other somehow. Felt calmer in general, so I feel like I saw more blue. Or the cause and effect might be backward, but still felt like it interacted." (subject 3)

"...it's me, I feel the sense of agency through controlling my EDA and matching my pulse... feeling myself makes me relaxed. and I am also confused a little (if I felt right)." (subject 4)

"I felt like the umbrella knew the energy flowing inside of me. The influenced visualization influenced me again so it felt a bit like a spiral." (subject 7)

"When red, I was truly relatively active." (subject 8)

"I feel that I can control the umbrella; Most of the time I feel my way; color-sanity is overwhelming; the umbrella is my shell, the upper part covers me and expresses me; the lower part passively accepts." (subject 16)

"Not sure, but it stood stable whenever my mind was stable." - (subject 18)

"The change of the visualization seems to represent my heart rate." - (subject 21)

In the inversion session, 4 participants thought the visualization represented part of their feeling and 12 participants thought they felt being influenced rather than being represented, while 5 thought it was not related to his feeling:

"Maybe the blue light represents my excitement." (subject 7)

"I think in this session the change and speed of the colors was opposite than before. The red was calmer, and the blue blinks were faster." (subject 10)

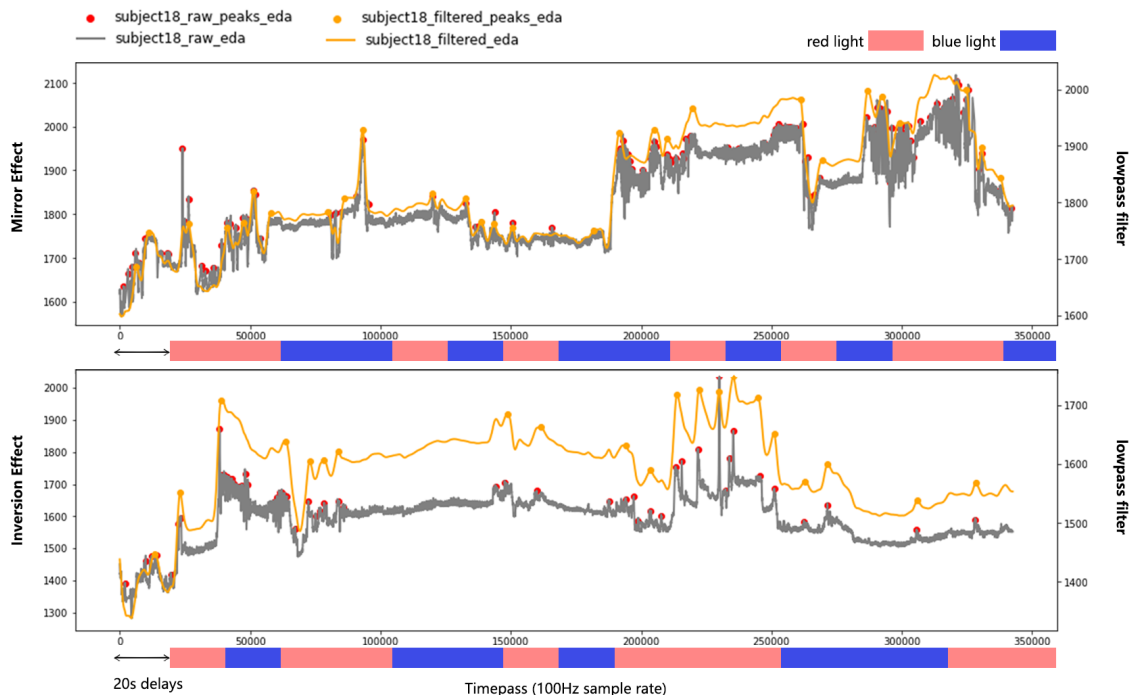
"...activity measurement of some sort." (subject 18)

"When the body is dynamic and static, the flickering frequency seems to be different." (subject 19)

"When i was going faster, it would turn red." (subject 20)

**6.2.2 Biometric Results.** Participants' physiological arousal was significantly increased with biofeedback patterns compared to no biofeedback in terms of pNN50. In terms of RMSSD, the inversion effect showed a significantly higher HRV performance than the baseline, while the mirror effect had a lower RMSSD performance.

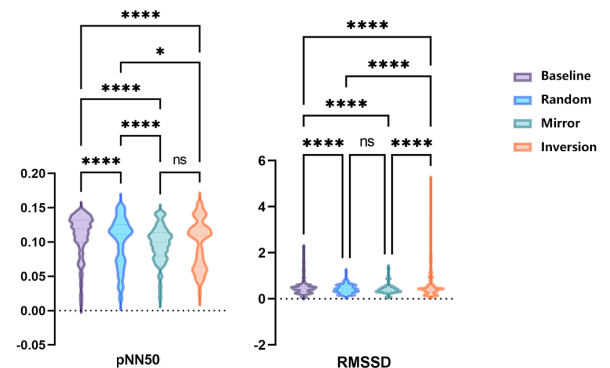




**Figure 8: Rainy Day User Study: EDA data of participant 18 (upper: Mirror Effect; lower: Inversion Effect). The raw EDA data from 12-bit ADC (0–4095 range) is depicted in gray; red markers depict recognized peaks in skin conductivity (local maxima) from raw data (left y scale). The low-pass filtered data (right Y scale) is depicted in orange; orange markers depict recognized peaks in skin conductivity (local maxima) from filtered data.**

In terms of SCR, peaks preprocessed from EDA raw data (100 Hz) were counted for real-time calculations as a basis for color feedback. Considering the individual differences in the biofeedback of different subjects, we took subject 18 as an example to simulate the color changes (see Figure 8) they experienced during the mirror session and the inversion session (light flicker frequency was reversed). The frequency of color switching could be speculated to correspond to the frequency of short-term emotional ups and downs. Through observation, we found that the emotional ups and downs under the influence of the mirror effect are relatively more frequent than the inversion effect. In addition, the changes in the peaks filtered by the lowpass filter in the figure were basically the same as the real-time data.

In terms of HRV, we calculated the aggregation of pNN50 and RMSSD from the preprocessed BVP raw data (100 Hz) under four conditions and performed the statistical analysis. According to one-way ANOVA, aggregated pNN50 ( $F(3, 13138) = 103.1, p < .0001$ ) and aggregated RMSSD ( $F(3, 19610) = 186.4, p < .0001$ ) significantly differed across the four conditions. We also conducted pairwise comparisons (see Figure 9) and found that the relaxation level (pNN50 [8, 26, 51]) in the session with biofeedback was significantly higher than that in both baseline ( $p < .0001$ ) and random sessions ( $p < .0001$ ). As for changes in cognitive load and stress level (RMSSD [1, 63]), the mirror session was significantly lower than the baseline session ( $p < .0001$ ) while the inversion session was significantly higher than the sessions with no ( $p < .0001$ ) or random



**Figure 9: HRV aggregation changes over four conditions. Symbols: ns =  $p > 0.05$ ; \* =  $p < 0.05$ ; \*\*\*\* =  $p < 0.0001$ .**

( $p=0.0194$ ) visualization. Furthermore, participants would show a significantly lower score in terms of RMSSD when experiencing the inversion effect (Mean:0.422, SD:0.208) than the mirror effect (Mean:0.572, SD:0.591) while there was no significant difference between mirror and inversion effect in terms of pNN50.



Figure 10: Body maps produced by participants over different sessions

## 7 DISCUSSION

### 7.1 Feasibility of Emotion Reflection and Regulation

The results of the sensing test showed the sensing availability of the umbrella handle. Comparing the BVP and EDA signals collected from the established sensing device (the wristband) with the signals collected from the handle suggests that the handle could produce similar trends of HRV pNN50, Phasic, and key SCR peaks (see Figure 5).

The feedback test provides a deeper understanding of the relationship between visual feedback design and emotions. The results of the feedback test show that participants had significantly higher physiological arousal under the blue light than under the red light in terms of EDA Phasic, while the average pNN50 suggests that under the blue light the participants experienced the highest state of relaxation and sustained attention [8, 26, 51]. This suggests the feasibility of using color feedback to reflect and influence people's emotional feelings. Considering that the visual feedback design of the umbrella is mainly based on physiological data, we balanced the psychological and physiological aspects of the subject's interpretation of the emotional response to the visual feedback, and thus propose an effective and iterative biofeedback design scheme. We further observed the interview data through the results of a semantic analysis and self-reporting of mean changes of SAM, and we found that participants' subjective evaluation of blue and red was opposite to physiological arousal. Possible reasons: color association may be different depending on cultural meaning of the color, upbringing, and personal experience. For example, one outlier had the opposite feeling toward blue and red than the other subjects. Associated with his memory in New Zealand when he was young, he was afraid to go out at night to the waste bin, crossing a dark road with a blue street light. He was also the one who agreed that red light helps him feel calm, since to him it was associated with the bar atmosphere in Tokyo.

After a few rounds of prototype iterations, we developed the final version of Affective Umbrella, which was used in the user study. In terms of self-reported SAM scores, participants would show higher emotional arousal and lower dominance scores (see Figure 7) when experiencing biofeedback patterns than without visualization in the baseline session. Most of the participants were

aware of the difference in manipulation between the random session and the biofeedback sessions (mirror and inversion). Valence level was rarely affected. In addition, from the check-out interviews, we found that most of the participants could interpret the emotional link matching the expected patterns. Based on the check-out interviews conducted after the visualization tests, our research questions (RQ1-RQ3) were positively answered. Among three visual effects (random, mirror, inversion), the participants' physiological arousal increased significantly with biofeedback patterns compared to no biofeedback in terms of pNN50. In terms of RMSSD, the inversion effect augmented participants with significantly higher HRV performance than the baseline, while the mirror effect caused lower RMSSD performance.

### 7.2 Implications for Biofeedback Loop Design

Apart from demonstrating the design concept, system, and iterative evaluation, we also discussed the design considerations towards visual feedback as a reflective effect for emotion regulation, which other designers might consider when developing their system. In the biofeedback loop study, we not only compared between conditions with and without visualization, but also explored potential biofeedback types: mirror and inversion. The two types of loop design can bring different experiences in terms of emotion interpretation and regulation. Our initial results suggest that the mirror type could be more effective in increasing the arousal level than the inversion type. Furthermore, as a bodily experience, the biofeedback loop could lead to a different experience.

### 7.3 Affective Dynamics in a Ubiquitous Context

This study provides an evaluation method for collecting physiological data in dynamic contexts, as demonstrated in our user study during rainy weather at night. Beyond this, we believe that the system could be applied to a variety of other ubiquitous contexts. Its affective dynamics about arousal change are not significantly related to their affects on the cognitive level, so that the user's emotional state would not be exposed publicly; but it would function as an emotional regulation augmentation. Our current design comes in the form of an umbrella for its non-invasive position for detection of EDA and BVP, the possibility for ubiquitous wear, and easy activation in needed scenarios. Vision is one of the windows for receiving environmental information, and reconstruction of context

design proposes a way to sense our body and perceive the links between the environment and us. For a similar research purpose, this study could provide an effective design approach bridging daily assessment in different personalized experiences with a greater understanding of our physiology.

## 7.4 Limitation and Future work

In terms of limitations and future work, we collected both EDA and BVP data during the user study. However, as a movement-sensitive sensing modality, not all of the EDA data turned out to be able to analyze. Furthermore, the body map (see Figure 10) could provide more insights about participants' reflection on experience mediated by biofeedback technologies inspired by the method in medical practice, which is used to locate pain in and around the body[39], but it still needs to be further analyzed with greater concern.

In the future, we could test other positions to collect and use EDA and BVP data (e.g. head or ear) in terms of stability. Moreover, the current feedback was triggered by calculating the SCR peaks over a certain period. There could be further explorations to design feedback actuation, such as implementing a machine learning model to automatically predict emotional states. We could also improve the prototype in terms of size, battery storage, and weight. We would keep working on streaming data via mobile phone network instead of wireless UDP communication to enable a more unconstrained setup.

## 8 CONCLUSION

This work presents Affective Umbrella, a novel system with integrated heart and electrodermal activity sensors in the handle. The system is able to record and analyze these physiological data in real time and visualize them back to the user on the umbrella canopy using fiber optics and LEDs. The general goal is to build a biofeedback system for emotion regulation as a means for human augmentation.

We take an iterative approach to design and evaluate the system. First, a comparison of the handle with the baseline wristband showed that it could be used as a possible sensing location in the sensing test (N=8). Then we presented self-reported blue and red feedback with the SAM scale, interview transcripts, and the corresponding physiological changes for 18 participants. The results demonstrate the correlation of colors eliciting physiological arousal in a user study (N=21) and the feasibility of mirror and inverse brightness changes of colors, thereby exploring the connection between body and mind through somaesthetic appreciation.

In addition to deepening our understanding of biofeedback and how emotions are reflected and regulated, this study explores the implications of designing biofeedback loop systems and emotional dynamics in ubiquitous settings. We hope that the questions raised concerning artificial and natural experience, self-discovery, and awareness in different contexts, as well as the technical contribution of this iterative approach for a biofeedback design, would provide some help and inspiration to those seeking to design similar systems or experiences.

## ACKNOWLEDGMENTS

This work is supported by IoT Accessibility Toolkit JST Presto Grant Number JPMJPR2132.

## REFERENCES

- [1] Muneeb Intiaz Ahmad, David A Robb, Ingo Keller, and Katrin Lohan. 2020. Towards a multimodal measure for physiological behaviours to estimate cognitive load. In *International Conference on Human-Computer Interaction*. Springer, 3–13.
- [2] Miquel Alfaras, Vasiliki Tsaknaki, Pedro Sanches, Charles Windlin, Muhammad Umair, Corina Sas, and Kristina Höök. 2020. From biodata to somadata. In *Proceedings of the 2020 CHI Conference on Human Factors in Computing Systems*. 1–14.
- [3] John L. Andreassi. 2010. *Psychophysiology: Human behavior and physiological response*. Psychology Press.
- [4] Karen Anne Cochrane, Kristina Mah, Anna Ståhl, Claudia Núñez-Pacheco, Madeleine Balaam, Naseem Ahmadi, and Lian Loke. 2022. Body Maps: A Generative Tool for Soma-based Design. In *Sixteenth International Conference on Tangible, Embedded, and Embodied Interaction*. 1–14.
- [5] Bradley M Appelhans and Linda J Luecken. 2006. Heart rate variability as an index of regulated emotional responding. *Review of general psychology* 10, 3 (2006), 229–240.
- [6] Mathias Benedek and Christian Kaernbach. 2010. A continuous measure of phasic electrodermal activity. *Journal of neuroscience methods* 190, 1 (2010), 80–91.
- [7] Adrian Borrego, Jorge Latorre, Mariano Alcañiz, and Roberto Llorens. 2019. Reliability of the Empatica E4 wristband to measure electrodermal activity to emotional stimuli. In *2019 International Conference on Virtual Rehabilitation (ICVR)*. IEEE, 1–2.
- [8] Patricia J Bota, Chen Wang, Ana LN Fred, and Hugo Plácido Da Silva. 2019. A review, current challenges, and future possibilities on emotion recognition using machine learning and physiological signals. *IEEE Access* 7 (2019), 140990–141020.
- [9] Wolfram Boucsein. 2012. *Electrodermal activity*. Springer Science & Business Media.
- [10] Tianqin Cai, Liming Liu, and Jiahui Tang. 2018. E-umbrella: A Multifunction Emotion Improvement Umbrella. (2018).
- [11] Kanyu Chen, Jiawen Han, George Chernyshov, Christopher Kim, Ismael Rasa, and Kai Kunze. 2021. Affective Umbrella—Towards a Novel Sensor Integrated Multimedia Platform Using Electrodermal and Heart Activity in an Umbrella Handle. In *20th International Conference on Mobile and Ubiquitous Multimedia*. 208–210.
- [12] Kyung Yun Choi and Hiroshi Ishii. 2020. ambienBeat: Wrist-worn mobile tactile biofeedback for heart rate rhythmic regulation. In *Proceedings of the fourteenth international conference on tangible, embedded, and embodied interaction*. 17–30.
- [13] Caroline Claisse, Muhammad Umair, Abigail C Durrant, Charles Windlin, Pavel Karpashevich, Kristina Höök, Vasiliki Tsaknaki, Pedro Sanches, and Corina Sas. 2022. Tangible Interaction for Supporting Well-being. In *CHI Conference on Human Factors in Computing Systems Extended Abstracts*. 1–5.
- [14] Karen Cochrane, Yidan Cao, Audrey Girouard, and Lian Loke. 2022. Breathing Scarf: Using a First-Person Research Method to Design a Wearable for Emotional Regulation. In *Sixteenth International Conference on Tangible, Embedded, and Embodied Interaction*. 1–19.
- [15] Karen Cochrane, Lian Loke, Matthew Leete, Andrew Campbell, and Naseem Ahmadi. 2021. Understanding the first person experience of walking mindfulness meditation facilitated by EEG modulated interactive soundscape. In *Proceedings of the Fifteenth International Conference on Tangible, Embedded, and Embodied Interaction*. 1–17.
- [16] Jérémy Frey. 2016. Remote heart rate sensing and projection to renew traditional board games and foster social interactions. In *Proceedings of the 2016 CHI Conference Extended Abstracts on Human Factors in Computing Systems*. 1865–1871.
- [17] Thomas Fritz, Andrew Begel, Sebastian C Müller, Serap Yigit-Elliott, and Manuela Züger. 2014. Using psycho-physiological measures to assess task difficulty in software development. In *Proceedings of the 36th international conference on software engineering*. 402–413.
- [18] Yuichi Fujii, Fumio Kishino, Kazuyuki Fujita, and Yuichi Itoh. 2013. U-brella: A portable umbrella-shaped device for vibrationizing information. In *2013 IEEE Virtual Reality (VR)*. IEEE, 1–4.
- [19] Kazuyuki Fujita, Yuichi Itoh, Ai Yoshida, Maya Ozaki, Tetsuya Kikukawa, Ryo Fukazawa, Kazuki Takashima, Yoshifumi Kitamura, and Fumio Kishino. 2009. Funbrella: recording and replaying vibrations through an umbrella axis. In *Proceedings of the International Conference on Advances in Computer Entertainment Technology*. 66–71.
- [20] Oonagh M Giggins, Ulrik McCarthy Persson, and Brian Caulfield. 2013. Biofeedback in rehabilitation. *Journal of neuroengineering and rehabilitation* 10, 1 (2013), 1–11.
- [21] Emanuel Gollob, Magdalena Mayer, and Johannes Braumann. 2021. Using Robotics and AI To Physically Explore a Space of Aesthetic Possibilities: Defining a

- Physical Aesthetic Experience by the Targeted EEG Feedback of the Perceiver. In *Proceedings of the Fifteenth International Conference on Tangible, Embedded, and Embodied Interaction*. 1–8.
- [22] James J Gross. 1999. Emotion regulation: Past, present, future. *Cognition & emotion* 13, 5 (1999), 551–573.
- [23] Nitin Hardeniya, Jacob Perkins, Deepti Chopra, Nisheeth Joshi, and Iti Mathur. 2016. *Natural language processing: python and NLTK*. Packt Publishing Ltd.
- [24] Mariam Hassib, Mohamed Khamis, Susanne Friedl, Stefan Schneegass, and Florian Alt. 2017. Brainatwork: Logging cognitive engagement and tasks in the workplace using electroencephalography. In *Proceedings of the 16th international conference on mobile and ubiquitous multimedia*. 305–310.
- [25] Mariam Hassib, Stefan Schneegass, Philipp Eiglsperger, Niels Henze, Albrecht Schmidt, and Florian Alt. 2017. EngageMeter: A system for implicit audience engagement sensing using electroencephalography. In *Proceedings of the 2017 Chi conference on human factors in computing systems*. 5114–5119.
- [26] Jacob B Holzman and David J Bridgett. 2017. Heart rate variability indices as bio-markers of top-down self-regulatory mechanisms: A meta-analytic review. *Neuroscience & biobehavioral reviews* 74 (2017), 233–255.
- [27] Kristina Höök, Martin P Jonsson, Anna Ståhl, and Johanna Mercurio. 2016. So-maesthetic appreciation design. In *Proceedings of the 2016 CHI Conference on Human Factors in Computing Systems*. 3131–3142.
- [28] B Kent Houston. 1972. Control over stress, locus of control, and response to stress. *Journal of Personality and Social Psychology* 21, 2 (1972).
- [29] Hayeon Hwang. 2019. Expressive Tactile Controls. In *Proceedings of the Thirteenth International Conference on Tangible, Embedded, and Embodied Interaction*. 223–227.
- [30] Yusuke Kamiyama, Mai Tanaka, and Hiroya Tanaka. 2008. Oto-Shigure: An Umbrella-Shaped Sound Generator for Musical Expression.. In *NIME*. 352–353.
- [31] Yuichiro Katsumoto and Masa Inakage. 2007. Amagatana. In *Proceedings of the 15th ACM international conference on Multimedia*. 361–362.
- [32] Matthew C Keller, Barbara L Fredrickson, Oscar Ybarra, Stéphane Côté, Kareem Johnson, Joe Mikels, Anne Conway, and Tor Wager. 2005. A warm heart and a clear head: The contingent effects of weather on mood and cognition. *Psychological science* 16, 9 (2005), 724–731.
- [33] George Khut. 2006. Development and evaluation of participant-centred biofeedback artworks. *Unpublished doctoral exegesis, University of Western Sydney* (2006).
- [34] Basel Kikhia, Thanos G Stavropoulos, Stelios Andreadis, Niklas Karvonen, Ioannis Kompatsiaris, Stefan Sävenstedt, Marten Pijl, and Catharina Melander. 2016. Utilizing a wristband sensor to measure the stress level for people with dementia. *Sensors* 16, 12 (2016), 1989.
- [35] Theo A Klimstra, Tom Frijns, Loes Keijsers, Jaap JA Denissen, Quinten AW Raaijmakers, Marcel AG Van Aken, Hans M Koot, Pol AC Van Lier, and Wim HJ Meeus. 2011. Come rain or come shine: individual differences in how weather affects mood. *Emotion* 11, 6 (2011), 1495.
- [36] Peter J Lang, Mark K Greenwald, Margaret M Bradley, and Alfons O Hamm. 1993. Looking at pictures: Affective, facial, visceral, and behavioral reactions. *Psychophysiology* 30, 3 (1993), 261–273.
- [37] Robert W Levenson. 2003. Blood, sweat, and fears: The autonomic architecture of emotion. *Annals of the New York Academy of Sciences* 1000, 1 (2003), 348–366.
- [38] Zilan Lin, Kai Kunze, Atsuro Ueki, and Masa Inakage. 2020. Aromacue—a scent toolkit to cope with stress using the 4-7-8 breathing method. In *Proceedings of the Fourteenth International Conference on Tangible, Embedded, and Embodied Interaction*. 265–272.
- [39] Lian Loke and George Poonkhin Khut. 2014. Intimate aesthetics and facilitated interaction. In *Interactive Experience in the Digital Age*. Springer, 91–108.
- [40] Takashi Matsumoto and Sho Hashimoto. 2009. Pileus internet umbrella: tangible mobile interface of a lovely umbrella. In *Proceedings of the 3rd International Conference on Tangible and Embedded Interaction*. 41–42.
- [41] Takashi Matsumoto, Sho Hashimoto, and Naohito Okude. 2008. The embodied Web: embodied Web-services interaction with an umbrella for augmented city experiences. *Computer Animation and Virtual Worlds* 19, 1 (2008), 49–66.
- [42] P.Lang M.Bradley. 1994. Measuring Emotion: The Self-Assessment Semantic Differential Manikin and the Semantic Differential. *Journal of Behavior Therapy and Experimental Psychiatry* 25 (1994), 49–59. Issue 1.
- [43] Albert Mehrabian. 1980. Basic dimensions for a general psychological theory implications for personality, social, environmental, and developmental studies. (1980).
- [44] Jelena Mladenović. 2018. Considering gut biofeedback for emotion regulation. In *Proceedings of the 2018 ACM International Joint Conference and 2018 International Symposium on Pervasive and Ubiquitous Computing and Wearable Computers*. 942–945.
- [45] Sohichiro Mori and Makoto Oka. 2017. Proposal of Interaction Used Umbrella for Smartphone. In *Human Interface and the Management of Information: Information, Knowledge and Interaction Design*, Sakae Yamamoto (Ed.). Springer International Publishing, Cham, 579–588.
- [46] Xi Li Ni, Li Gao, Xi Xi Zhang, Yan Feng, and Yu Jing Jia. 2012. New Materials Application in Multifunctional Environmental-Protection Umbrella. In *Advanced Materials Research*, Vol. 600. Trans Tech Publ, 242–245.
- [47] James I Novak. 2020. Awareables: Beyond wearable technology. In *Proceedings of the Fourteenth International Conference on Tangible, Embedded, and Embodied Interaction*. 5–16.
- [48] Mirja Peltola. 2012. Role of editing of RR intervals in the analysis of heart rate variability. *Frontiers in physiology* 3 (2012), 148.
- [49] Robert Plutchik. 2001. The nature of emotions: Human emotions have deep evolutionary roots, a fact that may explain their complexity and provide tools for clinical practice. *American scientist* 89, 4 (2001), 344–350.
- [50] Stephen W Porges. 2007. The polyvagal perspective. *Biological psychology* 74, 2 (2007), 116–143.
- [51] Robert F Potter and Paul Bolls. 2012. *Psychophysiological measurement and meaning: Cognitive and emotional processing of media*. Routledge.
- [52] James A Russell. 1980. A circumplex model of affect. *Journal of personality and social psychology* 39, 6 (1980), 1161.
- [53] Elena Sabinson, Isha Pradhan, and Keith Evan Green. 2021. Plant-Human Embodied Biofeedback (pheB): A Soft Robotic Surface for Emotion Regulation in Confined Physical Space. In *Proceedings of the Fifteenth International Conference on Tangible, Embedded, and Embodied Interaction*. 1–14.
- [54] Pedro Sanches, Axel Janson, Pavel Karpashevich, Camille Nadal, Chengcheng Qu, Claudia Daudén Roquet, Muhammad Umair, Charles Windlin, Gavin Doherty, Kristina Höök, et al. 2019. HCI and Affective Health: Taking stock of a decade of studies and charting future research directions. In *Proceedings of the 2019 CHI Conference on Human Factors in Computing Systems*. 1–17.
- [55] Philip Schmidt, Attila Reiss, Robert Duerichen, and Kristof Van Laerhoven. 2018. Wearable affect and stress recognition: A review. *arXiv preprint arXiv:1811.08854* (2018).
- [56] Fred Shaffer, Rollin McCraty, and Christopher L Zerr. 2014. A healthy heart is not a metronome: an integrative review of the heart’s anatomy and heart rate variability. *Frontiers in psychology* 5 (2014), 1040.
- [57] Petr Slovák, Joris Janssen, and Geraldine Fitzpatrick. 2012. Understanding heart rate sharing: towards unpacking physiosocial space. In *Proceedings of the SIGCHI conference on human factors in computing systems*. 859–868.
- [58] Jaime Snyder, Mark Matthews, Jacqueline Chien, Pamara F Chang, Emily Sun, Saeed Abdullah, and Geri Gay. 2015. Moodlight: Exploring personal and social implications of ambient display of biosensor data. In *Proceedings of the 18th ACM conference on computer supported cooperative work & social computing*. 143–153.
- [59] Moe Sugawa, Taichi Furukawa, George Chernyshov, Danny Hynds, Jiawen Han, Marcelo Padovani, Dingding Zheng, Karola Marky, Kai Kunze, and Kouta Minamizawa. 2021. Boiling Mind: Amplifying the Audience-Performer Connection through Sonification and Visualization of Heart and Electrodermal Activities. In *Proceedings of the Fifteenth International Conference on Tangible, Embedded, and Embodied Interaction*. 1–10.
- [60] Mary L Swift. 1997. GraphPad prism, data analysis, and scientific graphing. *Journal of chemical information and computer sciences* 37, 2 (1997), 411–412.
- [61] Chiew Seng Sean Tan, Johannes Schöning, Kris Luyten, and Karin Coninx. 2014. Investigating the effects of using biofeedback as visual stress indicator during video-mediated collaboration. In *Proceedings of the SIGCHI Conference on Human Factors in Computing Systems*. 71–80.
- [62] Thomas Terkildsen and Guido Makransky. 2019. Measuring presence in video games: An investigation of the potential use of physiological measures as indicators of presence. *International journal of human-computer studies* 126 (2019), 64–80.
- [63] Michael Trimmel. 2015. Relationship of heart rate variability (HRV) parameters including pNNxx with the subjective experience of stress, depression, well-being, and every-day trait moods (TRIM-T): A pilot study. *The Ergonomics Open Journal* 8, 1 (2015).
- [64] Vasiliki Tsaknaki, Pedro Sanches, Tom Jenkins, Noura Howell, Laurens Boer, and Afroditi Bitzouni. 2022. Fabulating Biodata Futures for Living and Knowing Together. In *Designing Interactive Systems Conference*. 1878–1892.
- [65] Patricia Valdez and Albert Mehrabian. 1994. Effects of color on emotions. *Journal of experimental psychology: General* 123, 4 (1994), 394.
- [66] Marieke van Dooren, Joris H Janssen, et al. 2012. Emotional sweating across the body: Comparing 16 different skin conductance measurement locations. *Physiology & behavior* 106, 2 (2012), 298–304.
- [67] Daniela Villani, Claudia Carissoli, Stefano Triberti, Antonella Marchetti, Gabriella Gilli, and Giuseppe Riva. 2018. Videogames for emotion regulation: a systematic review. *Games for health journal* 7, 2 (2018), 85–99.
- [68] Reddy Virtanen, Ralf Gommers, Travis E Oliphant, Matt Haberland, Tyler Paddy, David Cournapeau, Evgeni Burovski, Pearu Peterson, Warren Weckesser, Jonathan Bright, et al. 2020. SciPy 1.0: fundamental algorithms for scientific computing in Python. *Nature methods* 17, 3 (2020), 261–272.
- [69] Bin Yu, Mathias Funk, Jun Hu, Qi Wang, and Loe Feijs. 2018. Biofeedback for everyday stress management: A systematic review. *Frontiers in ICT* 5 (2018), 23.